



USER'S INFORMATION MANUAL

For Models NT-16SE • NT-20SE

This book contains instructions for operating and maintaining the furnace.

INSTALLER: LEAVE THIS MANUAL WITH THE APPLIANCE.

CONSUMER: RETAIN THIS MANUAL FOR FUTURE REFERENCE.

Should you require further information, contact your dealer or nearest Suburban Service Center.

WARNING! Installation of this appliance must be made in accordance with the written instructions provided in this manual. No agent, representative or employee of Suburban or other person has the authority to change, modify or waive any provision of the instructions contained in this manual.

WARNING! Be sure the furnace and all ignition systems are "OFF" during any type of refueling and while vehicle is in motion or being towed.

WARNING! Improper installation, adjustment, alteration, service or maintenance can cause property damage, personal injury or loss of life. Refer to the installation instructions and/or owners manual provided with this appliance.

WARNING: If the information in this manual is not followed exactly, a fire or explosion may result causing property damage, personal injury or loss of life.

– Do not store or use gasoline or other flammable vapors and liquids in the vicinity of this or any other appliance.

– **WHAT TO DO IF YOU SMELL GAS**

- Evacuate all persons from the vehicle.
 - Shut off the gas supply at the gas container or source.
 - Do not touch any electrical switch, or use any phone or radio in the vehicle.
 - Do not start the vehicle's engine or electric generator.
 - Contact the nearest gas supplier or qualified service technician for repairs.
 - If you cannot reach a gas supplier or qualified service technician, contact the nearest fire department.
 - Do not turn on the gas supply until the gas leak(s) has been repaired.
- Installation and service must be performed by a qualified installer, service agency or the gas supplier.

Installer: leave this manual with the appliance.

Consumer: Retain this manual for future reference.

Due to high temperatures, the unit should be located out of traffic and away from furniture and draperies.

Children and adults should be alerted to the hazards of high surface temperatures and should stay away to avoid burns or clothing ignition.

Young children should be carefully supervised when they are in the same room as the unit.

Clothing or other flammable material should not be placed on or near the unit.

Any safety screen or guard removed for servicing the unit must be replaced prior to operating the unit.

The area around the unit must be kept clear from combustible materials, gasoline and other flammable vapors and liquids.

Installation and repairs should be done by a qualified service person. The unit should be inspected before use and at least annually by a qualified service person. More frequent cleaning may be required due to excessive lint from carpeting, bedding material, etc. It is imperative that control compartments, burners, and circulating air passageways of the unit be kept clean.

MAINTENANCE AND CLEANING

WARNING! If the user of this appliance fails to maintain it in the condition in which it was shipped from the factory or if the appliance is not used solely for its intended purpose or if appliance is not maintained in accordance with the instructions in this manual, then the risk of a fire and/or the production of carbon monoxide exists which can cause personal injury, property damage or loss of life.

CAUTION: Label all wires before disconnecting for servicing. Proper polarity must be observed so the furnace motor will run with the proper direction of rotation to insure correct air delivery. (See wiring diagram).

CAUTION: Label all wires prior to disconnection when servicing controls. Wiring error can cause improper and dangerous furnace operation.

Always verify proper operation of furnace after servicing.

Your furnace should be inspected by a qualified service agency yearly before turning the furnace on. Particular attention should be given to the following items.

1. Inspect furnace installation and vent termination to be sure furnace is properly secured in place (See Installation Instructions), that vent terminates to the atmosphere, and that vent tubes overlap properly (See Installing Vent Assembly).
2. Inspect chamber and venting to assure that these components are physically sound, without holes or excessive corrosion and that the installation and/or reinstallation is in accordance with Suburban's Installation Instructions. (Reference installation manual supplied with furnace.)

WARNING! It is imperative that the products of combustion be properly vented to atmosphere and that all combustion air supplied to burner be drawn from outside atmosphere.

3. Check the base on which furnace is mounted. Be sure it is physically sound, void of any sagging, deterioration, etc.
4. Inspect furnace, the venting and the gas piping to furnace for obvious signs of deterioration. Correct any defects at once.
5. Inspect combustion chamber for restrictions in exhaust or intake. It is imperative that the flow of intake combustion air and the flow of exhaust gases being expelled to the outside atmosphere not be obstructed. Any soot or loose debris should be blown out using compressed air.
6. Inspect all gaskets. If any gaskets show signs of leakage or deterioration, replace them. Safe operation of the furnace depends on all gaskets being tight.
7. Inspect return air inlet openings to the furnace. Remove any restrictions to assure adequate air flow.

You, as the owner/user, should inspect the furnace monthly during the heating season for presence of soot on vent. Operating the furnace under this condition could lead to serious property damage, personal injury or loss of life. If soot is observed on the vent, immediately shut the furnace down and contact a qualified service agency.

Listed below are several safety related items that you should follow during the heating season to assure continued safe operation of the furnace.

1. Inspect furnace venting. Venting must be free of obstructions, void of soot and properly terminated to the atmosphere.

WARNING! Do not install screens over the vent for any reason. Screens will become restricted and cause unsafe furnace operation. Accessories are being marketed for RV products which we do not recommend. For your safety, only factory authorized parts are to be used on your furnace.

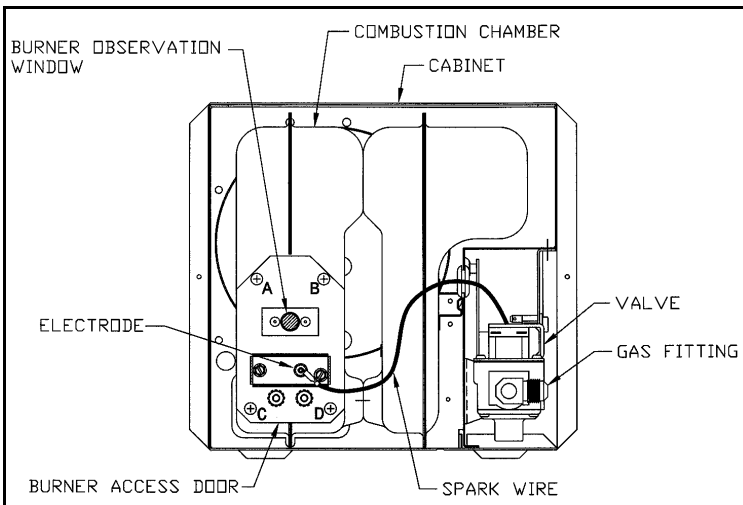

Figure 1

2. Periodically observe the main burner flame to assure it is burning with a hard blue flame with well defined burner ports (See Figure 2). If flame appears yellow or burner has a lazy flame, shut furnace down. It is possible that burner needs cleaning or replaced. To inspect the main burner, remove the four (4) screws (A, B, C and D) securing the burner access door to the combustion chamber (See Figure 1). If excessive rust and corrosion are present on burner surface, the burner must be thoroughly cleaned or replaced. The burner may be cleaned using a steel wire brush and blown clean using high compression air. Contact a qualified service person for assistance.

NOTE: To observe flame, cabinet front must be removed. Operation of burner can then be observed through the viewing window on front of chamber. (See Figure 1.)

3. Periodically inspect the vent for obstructions or presence of soot. Soot is formed whenever combustion is incomplete. This is your visual warning that the furnace is operating in an unsafe manner. If soot is present, immediately shut furnace down and contact your dealer or a qualified service person.
4. Keep furnace clean. More frequent cleaning may be required due to excessive lint from carpeting, bedding material, etc. It is imperative that control compartments, burners and circulating air passageways of the appliance be kept clean.
5. The motor is permanently lubricated and requires no oiling.
6. Keep the furnace area clear of any combustible materials, gasoline or other flammable vapor and liquids.
7. Before operating furnace, check the location of the furnace vent to make sure it will not be blocked by the opening of any door on the trailer. If it can be blocked, do not operate the furnace with the door open.
8. Do not restrict the flow of combustion air or the warm air circulation to the furnace. To do so could cause personal injury and/or death.
9. Never operate the furnace if you smell gas. Do not assume that the smell of gas in your RV is normal. Any time you detect the odor of gas, it is to be considered life threatening and corrected immediately. Extinguish any open flames including cigarettes and evacuate all persons from the vehicle. Shut off gas supply at LP gas bottle. (See safety notice on front cover of this manual.)
10. Immediately shut furnace down and call a service agency if furnace cycles erratically or delays on ignition.

WARNING! Should overheating occur, or the gas supply fail to shut off, shut off the manual gas valve to the appliance before shutting off the electrical supply.

11. Never attempt to repair damaged parts. Always have them replaced by a qualified service agency.
12. Never attempt to repair the furnace yourself. Seek the help of a qualified service person.
13. Clothing or other flammable material should not be placed on or near the appliance.
14. Always follow the Operating Instructions. Do not deviate from the step-by-step procedures.
15. In any installation in which the vent of this appliance can be covered due to the construction of the RV or some special feature of the RV such as slide out, pop-up etc. always insure that the appliance cannot be operated by setting the thermostat to the positive "OFF" position and shutting off all electrical and gas supply to the appliance. Never operate furnace with vent covered.
16. When considering add-on rooms, porch or patio, attention must be given to the venting of your furnace. For your safety, do not terminate furnace vent inside add-on rooms, screen porch or onto patios. Doing so will result in products of combustion being vented into the room or occupied areas.

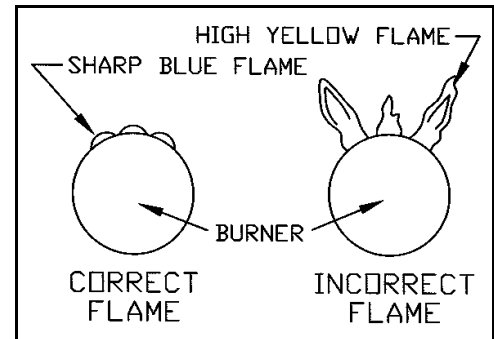

Figure 2

OPERATING INSTRUCTIONS

WARNING: Do not operate furnace while vehicle is in motion or being towed.

NOTE: During initial firing of this furnace a burn-off of excess paint and oils remaining from manufacturing process may cause "smoking" for 5 - 10 minutes.

FOR YOUR SAFETY READ BEFORE OPERATING

WARNING: If you do not follow these instructions exactly, a fire or explosion may result causing property damage, personal injury or loss of life.

- A. This appliance does not have a pilot. It is equipped with an ignition device which automatically lights the burner. Do **not** light the burner by hand.
- B. **BEFORE OPERATING** smell all around the appliance area for gas. Be sure to smell next to the floor because some gas is heavier than air and will settle on the floor.

WHAT TO DO IF YOU SMELL GAS

- Extinguish any open flame.
- Evacuate all persons from the vehicle.
- Shut off the gas supply at the gas container or source.
- Do not touch any electric switch or use any phone or radio in the vehicle.
- Do not start the vehicle's engine or electric generator.

- Contact the nearest gas supplier or qualified service technician for repairs.
 - If you cannot reach a gas supplier or qualified service technician, contact the nearest fire department.
 - Do not turn on the gas supply until the gas leak(s) has been repaired.
- C. Use only your hand to turn the handle on the manual shut off valve. Never use tools. If the handle will not turn by hand, don't try to repair it, call a qualified service technician. Force or attempted repair may result in a fire or explosion.
- D. Do not use this appliance if any part has been under water. Immediately call a qualified service technician to inspect the appliance and to replace any part of the control system and any gas control which has been under water.

OPERATING INSTRUCTIONS

1. **STOP!** Read the safety information above on this label.
2. Set the thermostat to lowest setting.
3. Turn off all electric power to the appliance.
4. The appliance is equipped with an ignition device which automatically lights the burner. Do **not** try to light the burner by hand.
5. Turn shut-off valve to "OFF". This furnace is equipped with a valve shut-off switch. With switch in "OFF" position, gas will not flow to burner nor will the furnace operate.
6. Wait five (5) minutes to clear out any gas. Then smell for gas including near the floor. If you then smell gas, **STOP!** Follow "B" in the safety information above on this label. If you don't smell gas, go to next step.
7. Turn on all electric power to the appliance. These units are for use with LP gas only. LP gas is heavier than air. Therefore, to better clear out any gas, the heater should be operated for five (5) minutes with the blower on and the gas off. If blower does not come on or stops before ignition cycle, go to shut down and contact your dealer or a local recreational vehicle service agency.
8. Turn shut-off valve to "ON".
9. Set thermostat to desired setting.
10. If the appliance will not operate, follow the instructions "To Turn Off Gas to Appliance" and call your service technician or gas supplier. NOTE: If the furnace should lock-out, the blower will go off in 5 minutes and remain off until unit is reset by reactivating thermostat.

TO TURN OFF GAS TO APPLIANCE

1. Set the thermostat to lowest setting, then move lever to "OFF" position.
2. Turn off all electric power to the appliance if service is to be performed.
3. Turn shut-off valve to "OFF". Do not force.

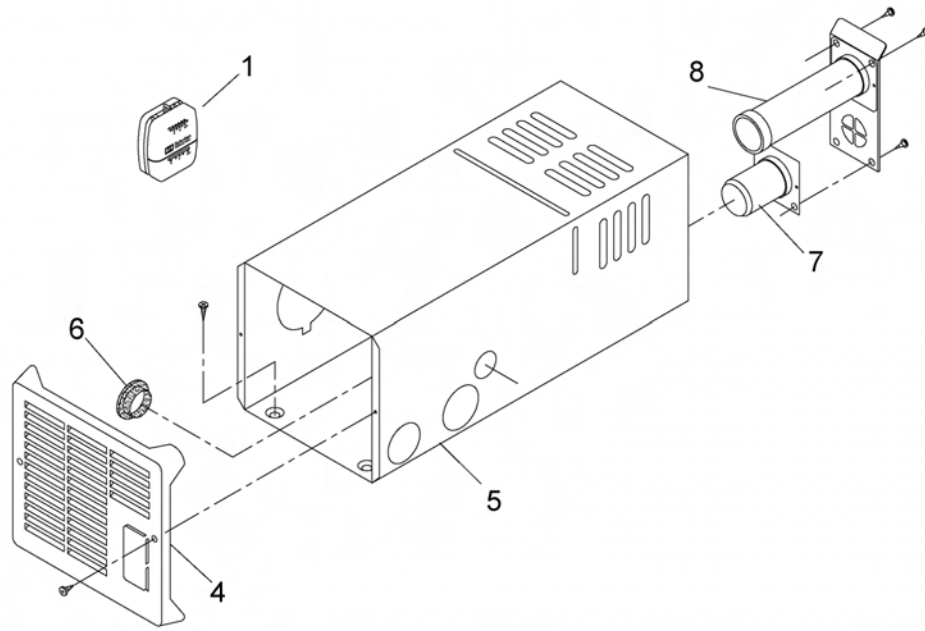

Figure 3

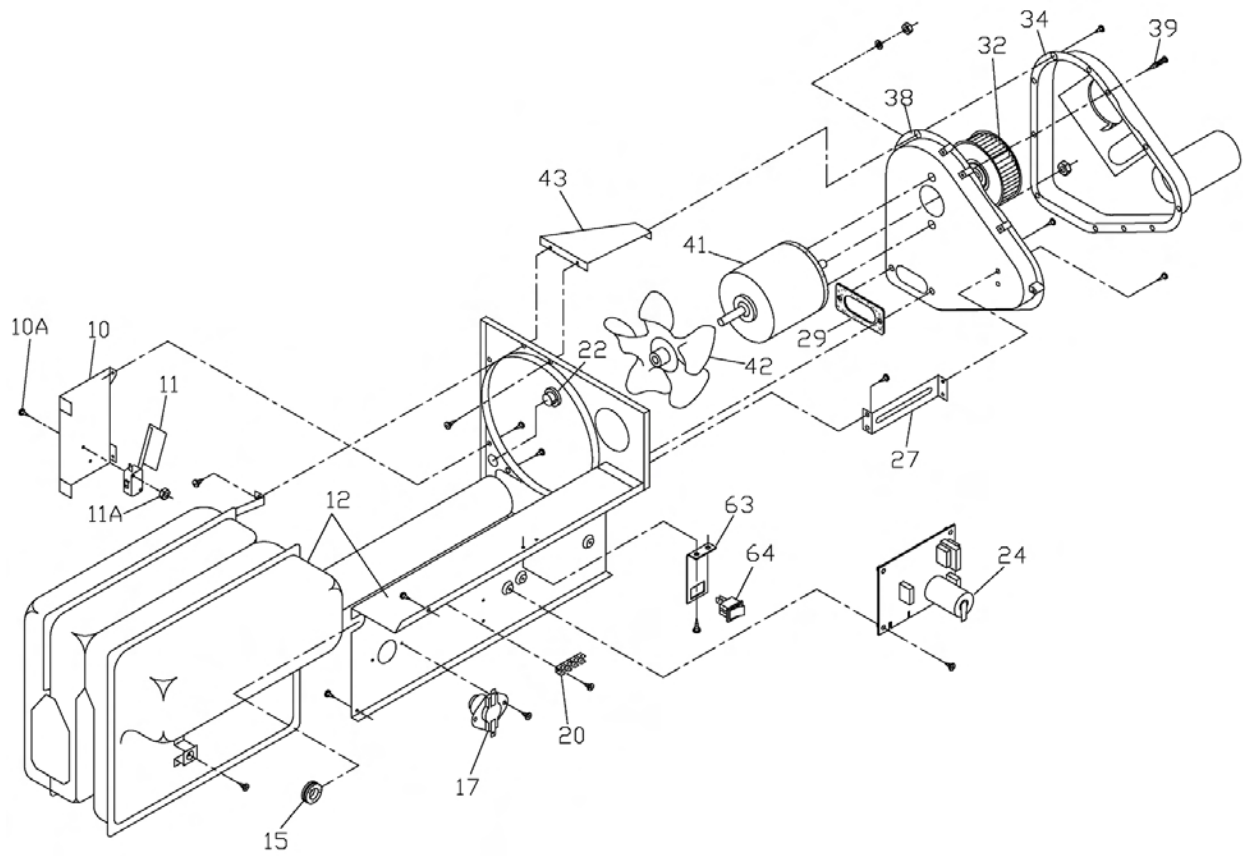

Figure 4

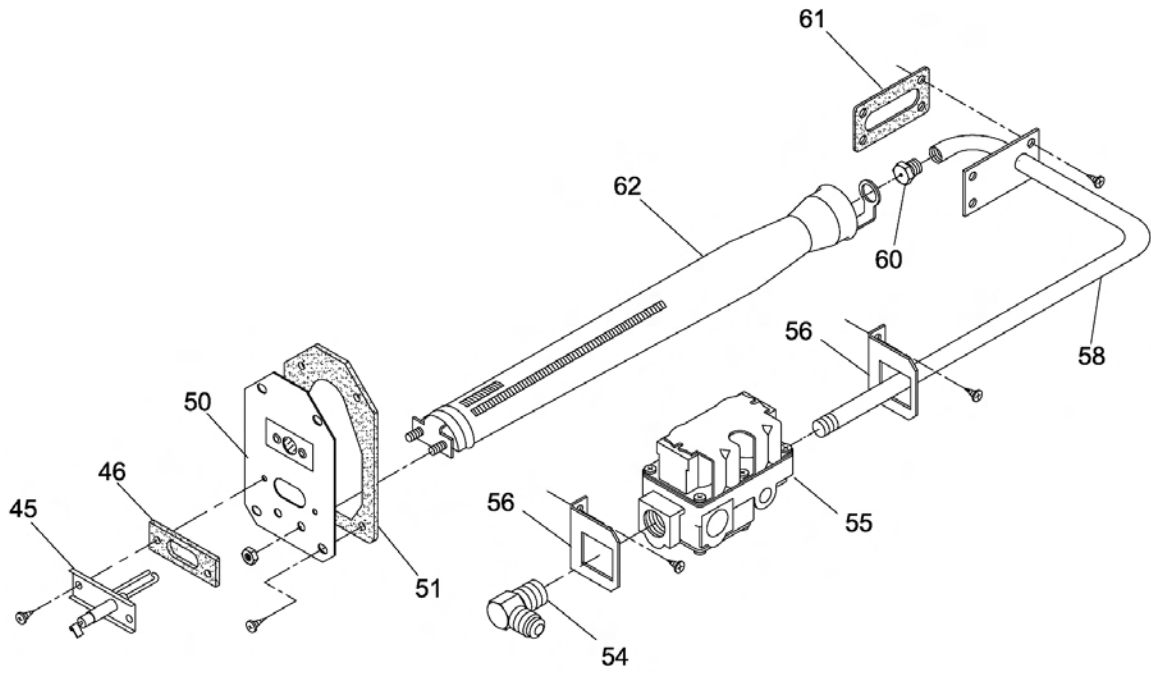

Figure 5

REPLACEMENT PARTS LIST

Models NT-12SE • NT-16SE • NT-20SE

Only factory authorized parts are to be used. Do not attempt to repair defective parts.

When ordering repair parts from your dealer, a Suburban Service Center, or distributor, always give the following information.

1. Part Number (Not Item No.)
2. Part Description
3. Model No., Serial No. and Date Code of Furnace
4. Number of Parts Required

Item No.	Part Number		Description
	NT-16SE	NT-20SE	
1	161154	161154	Thermostat (Suburban supplied thermostat not applicable to some models)
4	030785PW	030785PW	Cabinet Front (White)
	-----	030785SG	Cabinet Front (Gray)
	-----	030785GL	Cabinet Front (Light Gray)
5	101887	101887	Cabinet
6	070569	070569	Bushing
7	050712	050712	Tube, Intake (Standard) (5" Long)
	050711	050711	Tube, Intake (Special) (2 3/4" Long)
	050708	050708	Tube, Intake (Special) (7 3/4" Long)
8	260572	260572	Vent Cap and Exhaust Tube Assembly
10	062476	062476	Bracket, Microswitch Mounting
10A	121247	121247	Screw, #2 - 56 x 5/8 (2 Required)
11	230933	230933	Microswitch Assembly
11A	121951	121951	Nut, #2-56 (2 Required)
12	021187BK	021187BK	Combustion Chamber/Shield Assembly
15	070243	070243	Grommet
17	230635	230849	Limit Switch
20	230714	230714	Splicer
22	070270	070270	Bushing
24	520820	520820	Module Board
27	062392	062392	Stiffener Bracket, Combustion Air Housing
29	070450	070450	Gasket, Burner Tunnel
32	350082	350082	Wheel, Combustion Air
34	390876	390876	Housing Combustion Air (Rear)
38	390874	390874	Housing Combustion Air (Front)
39	121928	121928	Screw 6-19 X 1/2 PH. P.H. (10 Required)
41	520950	520950	Motor
42	350083	350083	Impeller, Room Air
43	063447	063447	Bracket, Combustion Air Housing Mounting
45	231931	231931	Electrode
46	070163	070163	Gasket, Electrode
50	030621	030621	Door, Burner Access
51	070398	070398	Gasket, Burner Access Door
54	170374	170374	Gas Fitting
55	161123	161123	Valve
56	063531	063531	Bracket, Manifold Mounting (2 Required)
58	170744	170744	Manifold Assembly
60	180224	180231	Orifice, Main Burner
61	070449	070449	Gasket, Manifold
62	010614	010614	Burner Assembly
63	063249	063249	Bracket, Switch, Mounting
64	232351	232351	Switch, ON/OFF

This page is intentionally left blank

TWO YEAR LIMITED WARRANTY SUBURBAN RECREATIONAL VEHICLE FURNACE

TWO YEAR LIMITED WARRANTY

This Suburban product is warranted to the original purchaser to be free from defects in material and workmanship under normal use and maintenance for a period of two years from date of purchase whether or not actual use begins on that date. It is the responsibility of the consumer/owner to establish the warranty period. Suburban does not use warranty registration cards for its standard warranty. You are required to furnish proof of purchase date through a Bill of Sale or other payment records.

Suburban will replace any parts that are found defective within the first two years and will pay a warranty service allowance directly to the recommended Suburban Service Center at rates mutually agreed upon between Suburban and its recommended service centers. Replacement parts will be shipped FOB the shipping point within the Continental United States, Alaska and Canada to the recommended service center performing such repairs. All freight, shipping and delivery cost shall be the responsibility of the owner. The exchanged part or unit will be warranted for only the unexpired portion of the original warranty. Before having warranty repairs made, confirm that the service agency is a recommended service center for Suburban. DO NOT PAY THE SERVICE AGENCY FOR WARRANTY REPAIRS; SUCH PAYMENTS WILL NOT BE REIMBURSED.

For warranty service, the owner/user should contact the nearest recommended Suburban Service Center, advising them of the model and serial numbers (located on the furnace) and the nature of the defect. Transportation of the RV to and from the Service Center and/or travel expenses of the Service Center to your location is the responsibility of the owner/user. A current listing of recommended service centers may be obtained from Suburban's website, www.rvcomfort.com. If you cannot locate a recommended service center locally, the service agency chosen to perform warranty repairs must contact our Service Department at 423-775-2131 for authorization before making repairs. Unauthorized repairs made will not be paid by Suburban.

THREE YEAR LIMITED WARRANTY ON HEAT EXCHANGER

The furnace heat exchanger is further warranted to be free from defects in material and workmanship during the third through fifth year after the date of original purchase. A replacement heat exchanger will be provided under the same conditions as stated in the two year warranty **EXCEPT** no labor reimbursement will be provided.

LIMITATION OF WARRANTIES

ALL IMPLIED WARRANTIES (INCLUDING IMPLIED WARRANTIES OF MERCHANTABILITY) ARE HEREBY LIMITED IN DURATION TO THE PERIOD FOR WHICH EACH LIMITED WARRANTY IS GIVEN. SOME STATES DO NOT ALLOW LIMITATIONS ON HOW LONG AN IMPLIED WARRANTY LASTS SO THE ABOVE LIMITATIONS MAY NOT APPLY TO YOU. THE EXPRESSED WARRANTIES MADE IN THIS WARRANTY ARE EXCLUSIVE AND MAY NOT BE ALTERED, ENLARGED, OR CHANGED BY ANY DISTRIBUTOR, DEALER OR OTHER PERSON WHOMSOEVER.

SUBURBAN WILL NOT BE RESPONSIBLE FOR:

1. Normal maintenance as outlined in the installation, operating and service instructions owner's manual including cleaning of component parts; such as, orifices and burners.
2. Initial checkouts and subsequent checkouts which indicate the furnace is operating properly, or diagnosis without repair.
3. Damage or repairs required as a consequence of faulty or incorrect installation or application not in conformance with Suburban instructions.
4. Failure to start and/or operate due to loose or disconnected wires; water or dirt in controls, fuel lines and gas tanks; restriction or alteration of return air circulation; low voltage.
5. Routine adjustments that may be required to the thermostat, electrode and burner.
6. Costs incurred in gaining access to the furnace.
7. Parts or accessories not supplied by Suburban.
8. Freight charges incurred from parts replacements.
9. Damage or repairs needed as a consequence of any misapplication, abuse, unreasonable use, unauthorized alteration, improper service, improper operation or failure to provide reasonable and necessary maintenance.
10. Suburban products whose serial number has been altered, defaced or removed.
11. Suburban products installed or warranty claims originating outside the Continental U.S.A., Alaska, Hawaii and Canada.
12. Damage as a result of floods, winds, lightning, accidents, corrosive atmosphere or other conditions beyond the control of Suburban.
13. ANY SPECIAL, INDIRECT OR CONSEQUENTIAL PROPERTY, ECONOMIC OR COMMERCIAL DAMAGE OF ANY NATURE WHATSOEVER. Some states do not allow the exclusion of incidental or consequential damages, so the above limitation may not apply to you.

NO REPRESENTATIVE, DEALER, RECOMMENDED SERVICE CENTER OR OTHER PERSON IS AUTHORIZED TO ASSUME FOR SUBURBAN MANUFACTURING COMPANY ANY ADDITIONAL, DIFFERENT OR OTHER LIABILITY IN CONNECTION WITH THE SALE OF THIS SUBURBAN PRODUCT.

This warranty gives you specific legal rights, and you may also have other rights which vary from state to state.

IF YOU HAVE A PRODUCT PROBLEM

FIRST:

If your RV has its original furnace and is still under the RV manufacturer's warranty, follow the steps described in your RV owner's manual.

SECOND:

Contact a conveniently located recommended Suburban Service Center. Describe to them the nature of your problem, make an appointment, if necessary, and provide for delivery of the furnace to the selected service center.

THIRD:

For the location of the nearest service center, refer to the listing provided or contact:

Suburban Manufacturing Company
Customer Service Department
676 Broadway Street
Dayton, Tennessee 37321
(423) 775-2131, Ext. 7101
www.rvcomfort.com

For future reference, you should record the following information

MODEL NUMBER _____

SERIAL NUMBER _____

STOCK NUMBER _____

DATE OF PURCHASE _____