



RECORD THIS UNIT INFORMATION FOR
FUTURE REFERENCE:
Model Number _____
Serial Number _____
Date Purchased _____

**579 Series BRISK AIR
590 Series BRISK AIR
591 Series HEAT PUMP
595 Series QUICK COOL
600 Series PENGUIN
630 Series PENGUIN**

**Roof Top Air Conditioners & Heat Pumps
Used With Part No. 3109226.005 & 3109407.001
Comfort Control Center Electronic Control Kit
Ducted**

THIS UNIT IS DESIGNED FOR OEM INSTALLATION
ALL INITIAL INSTALLATIONS MUST BE APPROVED BY THE DOMETIC CORP.

USA
SERVICE OFFICE
Dometic Corporation
509 South Poplar St.
LaGrange, IN 46761
260-463-4858

CANADA
Dometic Distribution
866 Langs Drive
Cambridge, Ontario
CANADA N3H 2N7
519-653-4390

**For Service Center
Assistance Call:**
800-544-4881



! WARNING

This manual must be read and understood before installation, adjustment, service, or maintenance is performed. This unit must be installed by a qualified service technician. Modification of this product can be extremely hazardous and could result in personal injury or property damage.

! AVERTISSEMENT

Lire et comprendre ce manuel avant de procéder à l'installation, à des réglages, de l'entretien ou des réparations. L'installation de cet appareil doit être effectuée par un réparateur qualifié. Toute modification de cet appareil peut être extrêmement dangereuse et entraîner des blessures ou dommages matériels.

**INSTALLATION
INSTRUCTIONS**

MODELS

57908.321	57915.531	59136.531	59516.603	59530.632
57908.521	57915.536	59136.536	59516.631	600312.321
57912.621	57915.541	59136.621	59528.601	600315.326
57912.622	57915.546	59136.631	59529.531	600312.421
57912.631	57915.621	59516.303	59529.601	600315.321
57915.322	57915.622	59516.331	59529.631	600315.421
57915.331	57915.631	59516.336	59530.531	630035.321
57915.421	59016.621	59516.501	59530.532	630035.421
57915.422	59136.321	59516.531	59530.536	
57915.521	59136.331	59516.536	59530.601	
57915.522	59136.521	59516.601	59530.631	

REVISION
Form No. 3109270.060 11/03
(Replaces 3109270.052)
(French 3109537.055)
©2003 Dometic Corporation
LaGrange, IN 46761

Important: These instructions must stay with unit. Owner read carefully.

SAFETY INSTRUCTIONS

This manual has safety information and instructions to help users eliminate or reduce the risk of accidents and injuries.

RECOGNIZE SAFETY INFORMATION



This is the safety-alert symbol. When you see this symbol in this manual, be alert to the potential for personal injury.

Follow recommended precautions and safe operating instructions.

UNDERSTAND SIGNAL WORDS

A signal word, **WARNING OR CAUTION** is used with the safety-alert symbol. They give the level of risk for potential injury.

! WARNING indicates a potentially hazardous situation which, if not avoided, could result in death or serious injury.

! CAUTION indicates a potentially hazardous situation which, if not avoided may result in minor or moderate injury.

CAUTION used without the safety alert symbol indicates, a potentially hazardous situation which, if not avoided may result in property damage.

Read and follow all safety information and instructions.

1. GENERAL INFORMATION

- A. Product features or specifications as described or illustrated are subject to change without notice.
- B. **This air conditioner is designed for:**
1. Installation on a recreational vehicle at the time the vehicle is manufactured.
 2. Mounting on the roof of a recreational vehicle.
 3. Connection to an air distribution system located in the ceiling/roof cavity of the recreational vehicle.
 4. Roof construction with rafters/joists on minimum of 16 inch centers.
 5. Minimum of 2.00" and maximum of 5.50" distance between roof to ceiling of recreational vehicle. Alternate installation methods will allow for roofs more than 5.50" thick.
- C. The ability of the air conditioner to maintain the desired inside temperature depends on the heat gain of the RV. Some preventative measures taken by the occupants of the RV can reduce the heat gain and improve the performance of the air conditioner. During extremely high outdoor temperatures, the heat gain of the vehicle may be reduced by:
1. Parking the RV in a shaded area
 2. Using window shades (blinds and/or curtains)
 3. Keeping windows and doors shut or minimizing usage
 4. Avoiding the use of heat producing appliances.

Operation on High Fan/Cooling mode will give optimum or maximum efficiency in high humidity or high outside temperatures.

Starting the air conditioner early in the morning and giving it a "head start" on the expected high outdoor ambient will greatly improve its ability to maintain the desired indoor temperature.

For a more permanent solution to high heat gain, accessories like A&E outdoor patio and window awnings will reduce heat gain by removing the direct sun. They also add a nice area to enjoy company during the cool of the evening.

D. Condensation

Note: The manufacturer of this air conditioner will not be responsible for damage caused by condensed moisture on ceilings or other surfaces. Air contains moisture and this moisture tends to condense on cold surfaces. When air enters the RV, condensed moisture may appear on the ceiling, windows, metal parts, etc. The air conditioner removes this moisture from the air during normal operation. Keeping doors and windows closed when this air conditioner is in operation will minimize condensed moisture on cold surfaces.

INSTALLATION INSTRUCTIONS DUCTED CCC

SPECIFICATIONS

MODEL NO.	NOMINAL CAPACITY (BTU/HR) COOLING	ELECTRICAL RATING	COMPRESSOR RATED LOAD AMPS	COMPRESSOR LOCKED ROTOR AMPS	FAN MOTOR RATED LOAD AMPS	FAN MOTOR LOCKED ROTOR AMPS	SCFM-HIGH SPEED MAXIMIN	TOTAL STATIC MAXIMIN " W. C.	REFRIGERANT R-22 (OZ)	MINIMUM WIRE SIZE*	AC CIRCUIT PROTECTION *** USER SUPPLIED	INSTALLED WEIGHT (POUNDS)	MINIMUM GENERATOR SIZE** 1 UNIT/2 UNITS
57906.321	7,180	115VAC, 60 HZ., 1PH.	6.9	36.0	2.5	5.8	325/250	0.55/0.90	16.0	12 AWG Copper up to 24'	20 Amp	75	2.5 KW / 4.0 KW
57908.521	7,100		6.6	34.0	2.5	5.8	325/250	0.55/0.90	17.0		20 Amp	75	2.5 KW / 4.0 KW
57912.321	11,000		9.5	53.0	2.5	5.8	325/250	0.55/0.90	15.5		20 Amp	94	2.5 KW / 4.0 KW
57912.531	11,000		8.0	53.0	2.5	5.8	325/250	0.55/0.90	18.5		20 Amp	94	2.5 KW / 4.0 KW
57912.621	11,000	8.5	48.3	2.5	5.8	325/250	0.55/0.90	16.0	20 Amp	94	20 Amp	94	2.5 KW / 4.0 KW
57912.622	11,000	8.5	48.3	2.5	5.8	325/250	0.55/0.90	18.0	20 Amp	94	20 Amp	94	2.5 KW / 4.0 KW
57912.631	13,500	8.5	48.3	2.5	5.8	325/250	0.55/0.90	18.0	20 Amp	94	20 Amp	94	2.5 KW / 4.0 KW
57915.321	13,500	12.1	60.0	2.5	5.8	325/250	0.55/0.90	15.0	20 Amp	104	20 Amp	104	3.5 KW / 5.0 KW
57915.322	13,500	11.4	58.0	2.5	5.8	325/250	0.55/0.90	15.5	20 Amp	104	20 Amp	104	3.5 KW / 5.0 KW
57915.331	13,500	11.4	58.0	2.5	5.8	325/250	0.55/0.90	15.5	20 Amp	100	20 Amp	100	3.5 KW / 5.0 KW
57915.421	13,500	11.5	50.0	2.5	5.8	325/250	0.55/0.90	13.5	20 Amp	100	20 Amp	100	3.5 KW / 5.0 KW
57915.422	13,500	11.5	50.0	2.5	5.8	325/250	0.55/0.90	14.5	20 Amp	100	20 Amp	100	3.5 KW / 5.0 KW
57915.521	13,500	12.1	59.0	2.5	5.8	325/250	0.55/0.90	16.0	20 Amp	94	20 Amp	94	3.5 KW / 5.0 KW
57915.522	13,500	12.1	59.0	2.5	5.8	325/250	0.55/0.90	16.5	20 Amp	94	20 Amp	94	3.5 KW / 5.0 KW
57915.531	13,500	12.1	59.0	2.5	5.8	325/250	0.55/0.90	16.5	20 Amp	94	20 Amp	94	3.5 KW / 5.0 KW
57915.536	13,500	12.1	59.0	2.5	5.8	325/250	0.55/0.90	16.5	20 Amp	94	20 Amp	94	3.5 KW / 5.0 KW
57915.541	13,500	11.3	62.0	2.5	5.8	325/250	0.55/0.90	16.0	20 Amp	94	20 Amp	94	3.5 KW / 5.0 KW
57915.546	13,500	11.3	62.0	2.5	5.8	325/250	0.55/0.90	16.0	20 Amp	94	20 Amp	94	3.5 KW / 5.0 KW
57915.621	13,500	11.0	54.4	2.5	5.8	325/250	0.55/0.90	16.0	20 Amp	94	20 Amp	94	3.5 KW / 5.0 KW
57915.622	13,500	11.0	54.4	2.5	5.8	325/250	0.55/0.90	16.5	20 Amp	94	20 Amp	94	3.5 KW / 5.0 KW
57915.626	13,500	11.0	54.4	2.5	5.8	325/250	0.55/0.90	16.0	20 Amp	94	20 Amp	94	3.5 KW / 5.0 KW
57915.631	13,500	11.0	54.4	2.5	5.8	325/250	0.55/0.90	16.5	20 Amp	94	20 Amp	94	3.5 KW / 5.0 KW
57915.731	13,500	11.3	56.0	2.5	5.8	325/250	0.55/0.90	15.0	20 Amp	94	20 Amp	94	3.5 KW / 5.0 KW
59016.521	15,000	12.9	71.0	2.5	6.0	350/250	0.40/1.10	26.5	20 Amp	101	20 Amp	101	3.5 KW / 5.0 KW
59016.526	15,000	12.9	71.0	2.5	6.0	350/250	0.40/1.10	26.5	20 Amp	104	20 Amp	104	3.5 KW / 5.0 KW
59016.531	15,000	12.9	71.0	2.5	6.0	350/250	0.40/1.10	26.5	20 Amp	104	20 Amp	104	3.5 KW / 5.0 KW
59016.621	15,000	12.9	77.0	2.5	6.0	350/250	0.40/1.10	26.5	20 Amp	104	20 Amp	104	3.5 KW / 5.0 KW
59136.321	15,000	12.7	60.0	2.5	6.0	325/250	0.40/1.10	34.0	20 Amp	104	20 Amp	104	3.5 KW / 5.0 KW
59136.521	15,000	12.9	71.0	2.5	6.0	325/250	0.40/1.10	34.5	20 Amp	104	20 Amp	104	3.5 KW / 5.0 KW
59136.531	15,000	12.8	79.0	2.5	6.0	325/250	0.40/1.10	31.5	20 Amp	105	20 Amp	105	3.5 KW / 5.0 KW
59136.536	15,000	12.8	79.0	2.5	6.0	325/250	0.40/1.10	31.5	20 Amp	105	20 Amp	105	3.5 KW / 5.0 KW
59136.621	15,000	12.0	77.0	2.5	6.0	325/250	0.40/1.10	34.5	20 Amp	105	20 Amp	105	3.5 KW / 5.0 KW
59136.631	15,000	12.0	77.0	2.5	6.0	325/250	0.40/1.10	34.5	20 Amp	105	20 Amp	105	3.5 KW / 5.0 KW
59516.303	15,000	12.7	60.0	2.0	5.6	325/250	0.40/1.10	29.0	20 Amp	104	20 Amp	104	3.5 KW / 5.0 KW
59516.331	15,000	11.5	50.0	2.5	5.8	325/250	0.40/1.10	28.0	20 Amp	94	20 Amp	94	3.5 KW / 5.0 KW

* For wire lengths over 24 ft. consult the National Electric Code for proper sizing.

** Dometic Corporation gives **GENERAL** guidelines for generator requirements. These guidelines come from experiences people have had in actual applications. When sizing the generator, the total power usage of your recreational vehicle must be considered. Keep in mind generators lose power at high altitudes and from lack of maintenance.

*** **CIRCUIT PROTECTION:** Time Delay Fuse or HACR Circuit Breakers Required.

INSTALLATION INSTRUCTIONS DUCTED CCC

SPECIFICATIONS

MODEL NO.	NOMINAL CAPACITY (BTU/HR) COOLING	ELECTRICAL RATING	COMPRESSOR RATED LOAD AMPS	COMPRESSOR LOCKED ROTOR AMPS	FAN MOTOR RATED LOAD AMPS	FAN MOTOR LOCKED ROTOR AMPS	SCFM-HIGH SPEED MAX/MIN	TOTAL STATIC MAX/MIN "W. C.	REFRIGERANT R-22 (OZ)	MINIMUM WIRE SIZE*	AC CIRCUIT PROTECTION *** USER SUPPLIED	INSTALLED WEIGHT (POUNDS)	MINIMUM GENERATOR SIZE** 1 UNIT/2 UNITS
59516.336	15,000	115VAC, 60 HZ., 1PH.	127	600	2.0	5.6	325/250	0.40/1.10	29.0	12 AWG Copper up to 24'	20 Amp	94	3.5KW/5.0 KW
59516.501	15,000		129	71.0	2.5	6.0	325/250	0.40/1.10	31.0		20 Amp	94	3.5KW/5.0 KW
59516.506	15,000		115	50.0	2.5	5.8	325/250	0.40/1.10	26.5		20 Amp	94	3.5KW/5.0 KW
59516.536	15,000		115	50.0	2.5	5.8	325/250	0.40/1.10	29		20 Amp	94	3.5KW/5.0 KW
59516.601	15,000		129	77.0	2.5	6.0	350/250	0.40/1.10	31.0		20 Amp	102	3.5KW/5.0 KW
59516.603	15,000		123	77.0	2.0	5.6	325/250	0.40/1.10	29.5		20 Amp	102	3.5KW/5.0 KW
59516.606	15,000		129	71.0	2.5	6.0	325/250	0.40/1.10	31.0		20 Amp	94	3.5KW/5.0 KW
59516.631	15,000		123	77.0	2.0	5.6	325/250	0.40/1.10	29.5		20 Amp	104	3.5KW/5.0 KW
59528.601	N/A		6.0	45.6	2.0	5.6	325/250	0.40/1.10	16.5		15 Amp	92	3.5KW/5.0 KW
59529.531	N/A		6.9	49.0	2.0	5.6	325/250	0.40/1.10	18.5		15 Amp	94	3.5KW/5.0 KW
59529.601	N/A		8.0	48.3	2.0	5.6	325/250	0.40/1.10	19.0		15 Amp	94	3.5KW/5.0 KW
59529.631	N/A		8.0	48.3	2.0	5.6	325/250	0.40/1.10	19.0		15 Amp	94	3.5KW/5.0 KW
59530.531	N/A		7.8	53.0	2.0	5.6	325/250	0.40/1.10	19.0		15 Amp	94	3.5KW/5.0 KW
59530.532	N/A		8.0	53.0	2.5	5.8	325/250	0.40/1.10	18.5		15 Amp	94	3.5KW/5.0 KW
59530.536	N/A		7.8	53.0	2.0	5.6	325/250	0.40/1.10	19.0		15 Amp	94	3.5KW/5.0 KW
59530.601	N/A		8.0	48.3	2.0	5.6	325/250	0.40/1.10	19.0		15 Amp	93	3.5KW/5.0 KW
59530.631	N/A		8.0	48.3	2.0	5.6	325/250	0.40/1.10	19.0		15 Amp	94	3.5KW/5.0 KW
59530.632	N/A		8.5	48.3	2.5	5.8	325/250	0.40/1.10	18.0		15 Amp	94	3.5KW/5.0 KW
600312.321	11,000		9.5	53.0	3.1	8.8	335/250	0.12/0.65	16.5		20 Amp	95	2.5KW/4.0 KW
600312.421	11,000		10.7	50.0	3.1	8.8	335/250	0.12/0.65	16.0		20 Amp	101	2.5KW/4.0 KW
600315.321	13,500		12.4	60.0	3.1	8.8	335/250	0.12/0.65	15.5		20 Amp	96	3.5KW/5.0 KW
600315.421	13,500		11.5	50.0	3.1	8.8	335/250	0.12/0.65	17.0		20 Amp	102	3.5KW/5.0 KW
630035.321	13,500		12.4	60.0	3.1	8.8	335/250	0.12/0.65	24.5		20 Amp	101	3.5KW/5.0 KW
630035.421	13,500		11.0	50.0	3.1	8.8	335/250	0.12/0.65	19.5		20 Amp	102	3.5KW/5.0 KW

* For wire lengths over 24 ft. consult the National Electric Code for proper sizing.

** Dometic Corporation gives **GENERAL** guidelines for generator requirements. These guidelines come from experiences people have had in actual applications. When sizing the generator, the total power usage of your recreational vehicle must be considered. Keep in mind generators lose power at high altitudes and from lack of maintenance.

*** **CIRCUIT PROTECTION:** Time Delay Fuse or HACR Circuit Breakers Required.

2. PRECAUTIONS

! WARNING

Improper installation may damage equipment, could endanger life, cause serious injury and/or property damage.

- A. Read Installation and Operating instructions carefully before attempting to start your air conditioner/heat pump installation.
- B. Dometic Corporation will not be liable for any damages or injury incurred due to failure in following these instructions.
- C. Installation must comply with the National Electrical Code and any State or Local Codes or regulations.
- D. DO NOT add any devices or accessories to this air conditioner/heat pump except those specifically authorized by Dometic.
- E. This equipment must be serviced by qualified personnel and some states require these people to be licensed.

3. CHOOSING LOCATION FOR THE AIR CONDITIONER/HEAT PUMP

This air conditioner is specifically designed for installation on the roof of a recreational vehicle (RV). When determining your cooling requirements, the following should be considered:

1. Size of RV;
2. Window area (increases heat gain);
3. Amount of insulation in walls and roof;
4. Geographical location where the RV will be used;
5. Personal comfort level required.

A. For One Unit Installation:

The air conditioner/heat pump should be mounted slightly forward of center (front to back) and centered from side to side.

B. For Two Unit Installations:

Install one air conditioner/heat pump one-third and one air conditioner/heat pump two-thirds from front of RV and centered from side to side.

It is preferred that the air conditioner/heat pump be installed on a relatively **flat and level** roof section measured with the RV parked on a level surface; however,

1. Up to an 8° slant to either side or front-to-back is acceptable on 600 and 630 Series Air Conditioners/heat pump.
2. Up to a 15° slant to either side or front-to-back is acceptable on 579, 590, 591 or 595 Series Air conditioners/heat pump.

AFTER LOCATION HAS BEEN SELECTED:

- a. Check for obstructions in the area where air conditioner/heat pump will be installed. See FIG. 1.
- b. The roof must be designed to support 130 pounds when the RV is in motion. Normally 200 pound static load design will meet this requirement.

CAUTION

It is the responsibility of the installer of this air conditioner/heat pump system to ensure structural integrity of the RV roof. Never create a low spot on the roof where water will collect. Water standing around the air conditioner/heat pump may leak into the interior causing damage to the product and the RV.

FIG. 1 AIR CONDITIONER/HEAT PUMP DIMENSIONS (On Top of Vehicle)

579, 590, 591 & 595 SERIES

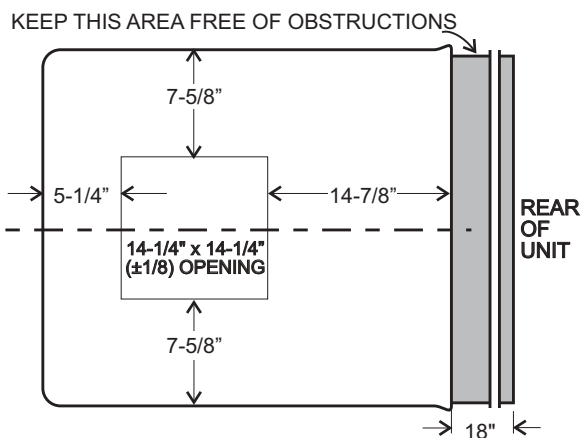

600 & 630 SERIES

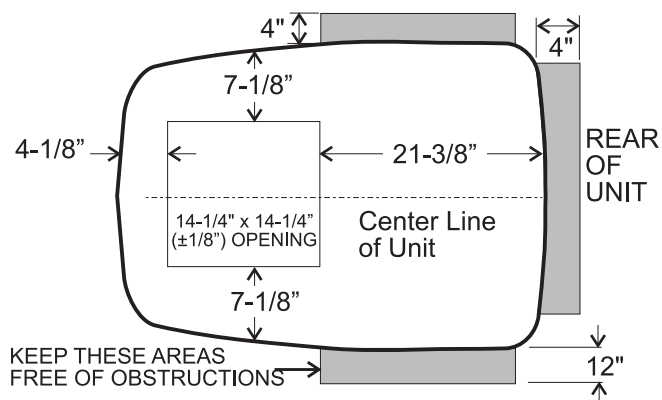

**4. AIR DISTRIBUTION SYSTEM
SIZING & DESIGN**

The Installer of this air conditioner/heat pump system must design the air distribution system for their particular application. Several requirements for this system **MUST** be met for the air conditioner/heat pump to operate properly. These requirements are as follows:

- A. The duct material must meet or exceed any agency or RVIA Standard that may be in existence at the time the RV is produced.
- B. All discharge air ducts must be properly insulated to prevent condensation from forming on their surfaces or adjacent surfaces during operation of the air conditioner/heat pump. This insulation must be R-7 minimum.
- C. Ducts and their joints must be sealed to prevent condensation from forming on adjacent surfaces during operation of the air conditioner/heat pump.
- D. Return air openings must have 40 square inches minimum free area including the filter.
- E. Return air to the air conditioner/heat pump must be filtered to prevent dirt accumulation on air conditioner/heat pump cooling surface.

⚠ CAUTION

It is the responsibility of the installer to insure the ductwork will not collapse or bend during and after the installation. Dometic Corporation will not be liable for roof structural or ceiling damage due to improperly insulated, sealed or collapsed ductwork.

**AIR DISTRIBUTION
DUCT SIZING & DESIGN CHART**

Return Air Cover Model	3105007.XXX 3105935.XXX	3308120.XXX Genesis Air Filtration System
Roof Cavity Depth	2.0 In. Min. - 5-1/2 In. Max.	2.0 In. Min. - 5-1/2 In. Max.
Duct Cross Sectional Area	21.0 Sq. In. Min.	32.0 Sq. In. Min.
Duct Size Depth Width Total Duct Length Duct Length (short run)	1-1/2 In. Min. - 2-1/2 In. Max. 7.0 In. Min. - 10.0 In. Max. 15.0 Ft. Min. - 40.0 Ft. Max. 1/3 Total Duct Length	2.0 In. Min. - 2-1/2 In. Max. 8.0 In. Min. - 10.0 In. Max. 15.0 Ft. Min. - 40.0 Ft. Max. 1/3 Total Duct Length
Register Requirements Number Required Per Run Register Free Air Area Distance From Duct End Distance From Elbow	4 Min. 14.0 Sq. In. 5.0 In. Min. - 8.0 In. Max. 15.0 In.	4 Min. 14.0 Sq. In. 5.0 In. Min. - 8.0 In. Max. 15.0 In.
Total System Static Air Pressure Blower at High Speed, Filter & Grill In Place	0.55 - 0.90 In. W.C. 579 Series 0.40 - 1.10 In. W.C. 590, 591, 595 Series 0.12 - 0.65 In. W.C. 600, 630 Series	0.55 - 0.90 In. W.C. 579 Series 0.40 - 1.10 In. W.C. 590, 591, 595 Series 0.12 - 0.65 In. W.C. 600, 630 Series

Note: Duct sizes listed are inside dimensions.

5. AIR DISTRIBUTION SYSTEM INSTALLATION

- A. Dometic Corporation recommends the basic configuration shown on page 8 for installing this air conditioner/heat pump system. We have found through testing that this configuration works best in most applications of this air conditioner/heat pump system. It is the responsibility of the Installer of this system to review each RV floor plan and determine the following:
1. Duct size
 2. Duct layout
 3. Register size
 4. Register location
 5. Thermostat location

These items must be determined in conjunction with the Air Distribution System and Sizing and Design Requirements listed in the chart on page 5.

Important: Alternate configurations and methods may be used which still allow the air conditioner/heat pump to operate properly; however, these alternate configurations and methods must be approved by the Dometic Corporation in writing. The following instructions are based upon the use of Dometic 3105007.XXX Return Air Kits, 3105935.XXX Quick Cool Kits, or 3308120.XXX Genesis Air Filtration System. The 3109226.XXX and 3109407.XXX Comfort Control Center Kits have the mounting bolts supplied for use with these kits.

B. ROOF AND CEILING OPENING PREPARATION

1. A 14-1/4" x 14-1/4" ($\pm 1/8$ ") opening must be cut through the roof and ceiling of the RV. This opening must be located between the roof reinforcing members.

⚠ WARNING

There may be electrical wiring between the roof and the ceiling. Disconnect 115 volt AC power cord and the positive (+) 12 volt DC terminal at the supply battery. Failure to follow this instruction may create a shock hazard causing death or severe personal injury.

2. Mark a 14-1/4" x 14-1/4" ($\pm 1/8$ ") square on the roof and carefully cut the opening.
3. Using the roof opening as a guide, cut the matching hole in the ceiling.
4. The opening created must be framed to provide adequate support and prevent air from being drawn from the roof cavity. Lumber 3/4" or more in thickness must be used. Remember to provide an entrance hole for power supply wiring and thermostat cable.
5. The 14-1/4" x 14-1/4" ($\pm 1/8$ ") opening is part of the return air system of the air conditioner/heat pump and must be finished in accordance with NFPA Standard 501C Section 2.7.
6. Route a copper 12 AWG (max. length 24'), with ground, supply line from the fuse or circuit breaker box to the roof opening.
 - a. This supply line must be located in the front portion of the 14-1/4" x 14-1/4" ($\pm 1/8$ ") opening.
 - b. The power supply **MUST** be on a separate 20 amp for models 579, 590, 591, 59516, 600 and 630 series, and 15 amp for models 59528, 59529 and 59530 Series Time Delay Fuse or HACR Circuit Breaker.
 - c. Make sure at least 15" of supply wire extends into the roof opening. This ensures easy connection at the junction box.
 - d. Wiring must comply with all National, State and Local Wiring Codes.
 - e. Use a steel sleeve and a grommet or equivalent methods to protect the wire where it passes into the opening.
7. See Section 6. Comfort Control Center, Remote Sensor and Cable Installation.

INSTALLATION INSTRUCTIONS DUCTED CCC

C. AIR DISTRIBUTION DUCT INSTALLATION

1. Install the Air Distribution Ducts in the RV Roof Cavity. The Distribution System must meet:
 - a. RV's requirements
 - b. System requirements listed in Section 4 on page 6 of this Manual. Terminate the start of the Duct at the back edge of the 14-1/4" x 14-1/4" ($\pm 1/8$ ") opening previously cut. See FIG. 2, 3, & 4.

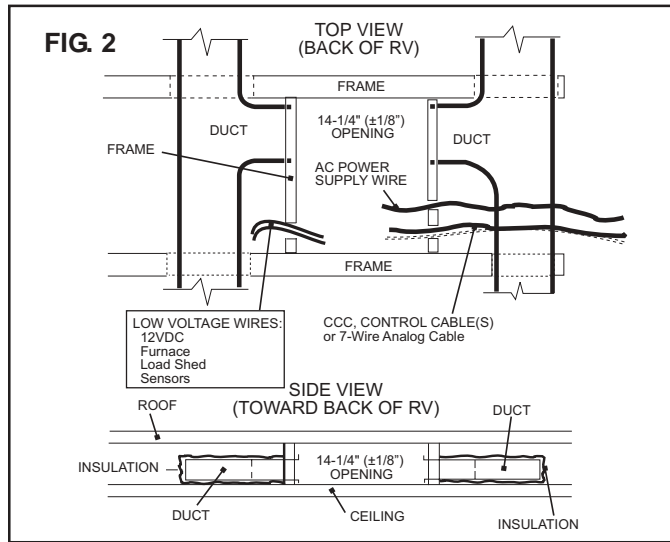

FIG. 3 Duct Size And Requirements For 3105007.XXX And 3105935.XXX Return Air Cover

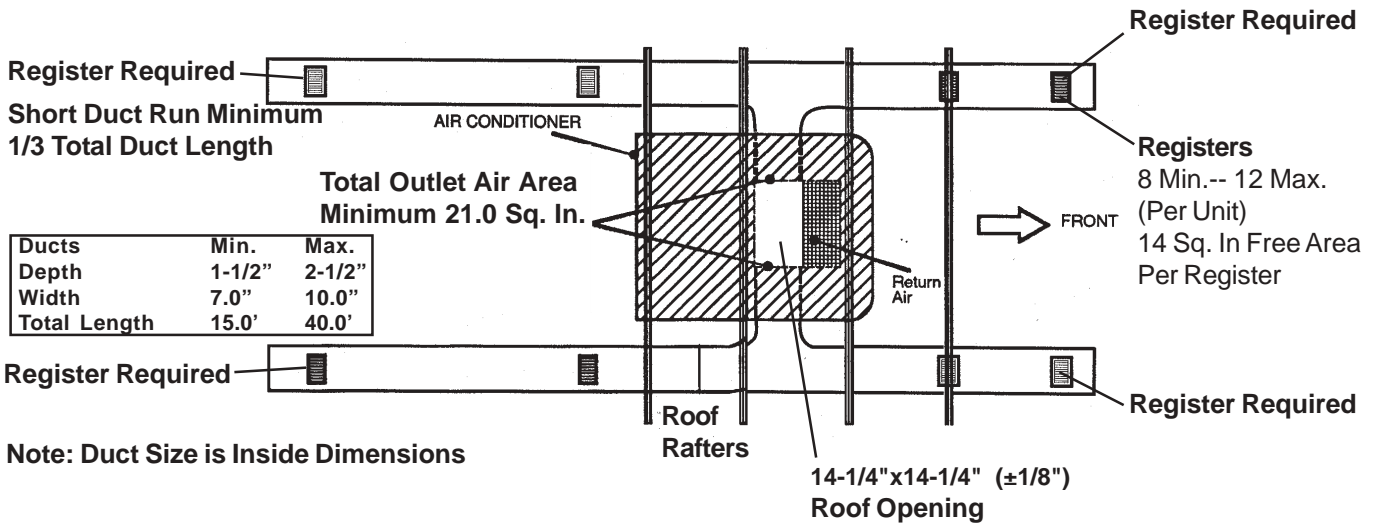
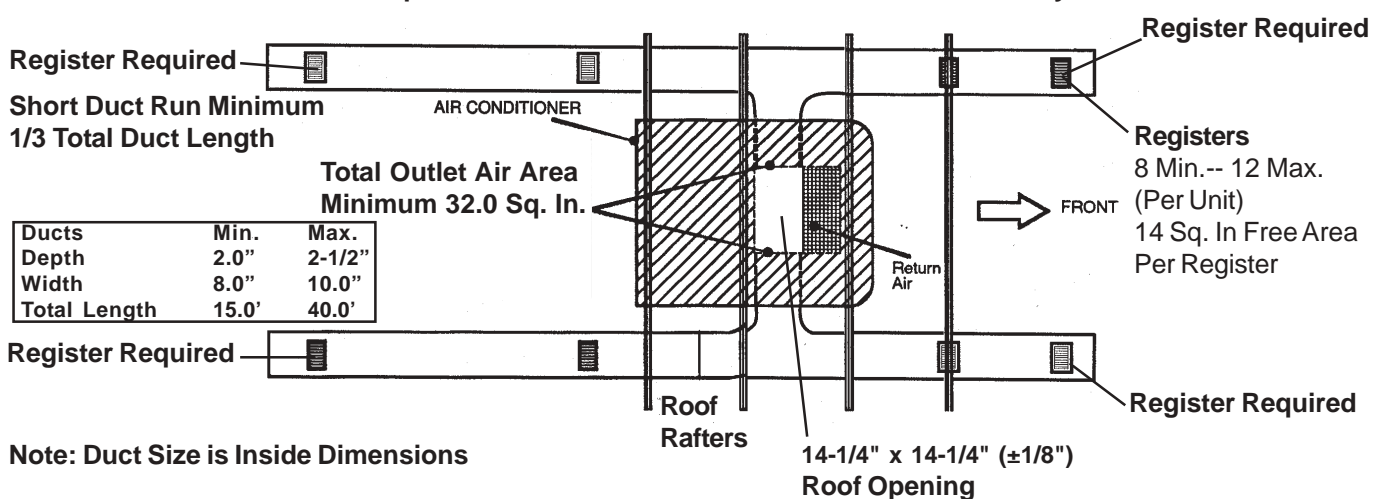

FIG. 4 Duct Size And Requirements For 3308120.XXX Genesis Air Filtration System



6. COMFORT CONTROL CENTER™, REMOTE SENSOR & CABLE INSTALLATION

A. LOCATION FOR COMFORT CONTROL CENTER™ AND REMOTE TEMPERATURE SENSOR

1. The proper location of the Comfort Control Center™ (CCC) is very important to ensure that it will provide a comfortable RV temperature. Observe the following general rules when selecting a location for the CCC or remote sensor.
 - a. Locate the CCC/remote sensor 54" above the floor.
 - b. Install CCC/remote sensor on a partition, **NEVER** on an outside wall.
 - c. **NEVER** expose CCC/remote sensor to direct heat from lamps, sun or other heat producing items.
 - d. Avoid locations close to doors that lead outside, windows or adjoining outside walls or directly under cabinets or overhangs which limit air movement.
 - e. Avoid locations close to supply registers and the air from them.
 - f. **NEVER** locate CCC/remote sensor in a room that is warmer or cooler than the rest of the coach - such as the kitchen.
 - g. The major living area is normally a good location.
2. If the system is to be used with a remote temperature sensor in all zones, the Comfort Control Center™ may be mounted anywhere that is convenient in the coach. Try to avoid hard to reach and hard to see areas. Follow a. - g. in step 1.

B. CONTROL CABLE

1. The cable that should be used is a flat, 4-conductor telephone type cable.
2. The cable must be terminated with two (2) RJ-11 telephone connectors. Refer to the crimp tool manufacture for crimping instructions.
3. The RJ-11 terminals must be connected to the control cable with the same polarity on both ends. **Pre-made standard telephone cable will not work.** See FIG. 5 & 5A.

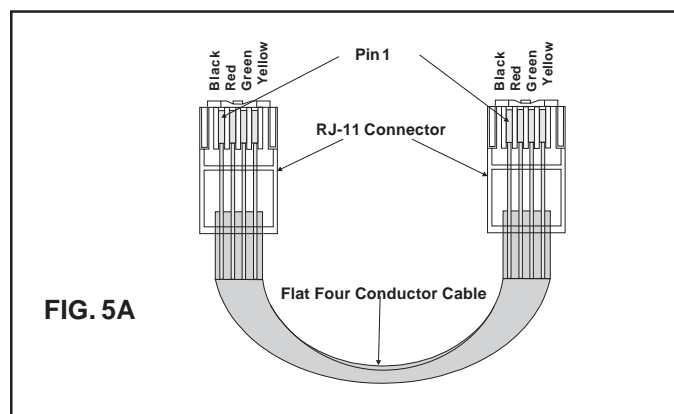
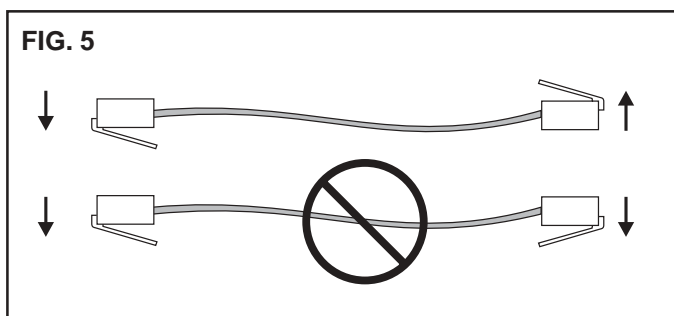

C. CABLE INSTALLATION

1. Route a dedicated 12VDC supply line (18 to 22 AWG) from the RV's converter or battery to the roof opening.
 - a. This supply line must be located in the front portion of the 14-1/4" x 14-1/4" (±1/8") opening.
 - b. Make sure that at least 15" of supply wire extends into the roof opening.
 - c. For multiple zone installation, this wiring is required in only one of the 14-1/4" x 14-1/4" (±1/8") openings.
2. Choose the shortest, direct route from the 14-1/4" x 14-1/4" (±1/8") opening to the Comfort Control Center™ (CCC) location selected, and route a 4-conductor flat control cable. Make sure at least 15" of wire extends into the opening and 6" extends from the wall at the Comfort Control Center™ (CCC) location.
3. If a remote temperature sensor is to be used, the connector end must be routed to the roof opening of the system which it will control. Make sure 15" of the sensor cable extends into the roof opening.
4. If an Energy Management System-EMS (load shed) is to be used with the control system, two wires must be routed to the roof opening of the zone to be managed. The signal required for this function is a normally open relay contact. When the EMS calls for the compressor to shut off, the relay contacts should close. Make sure that at least 15" of the EMS wires extend into the roof opening.
5. If system is to control a gas furnace, route two 18 gauge wires from the furnace to roof opening of the air conditioner that will control it. If more than one furnace is to be used, route the second set of wires to the second air conditioner. Make sure that 15" of wire extends into the opening.
6. In the event that other air conditioners are to be installed (additional zones) route an additional 4-conductor control cable between the other air conditioner (additional zones). Make sure 15" of wire extends into the roof opening. See FIG. 6.

INSTALLATION INSTRUCTIONS DUCTED CCC

FIG. 6

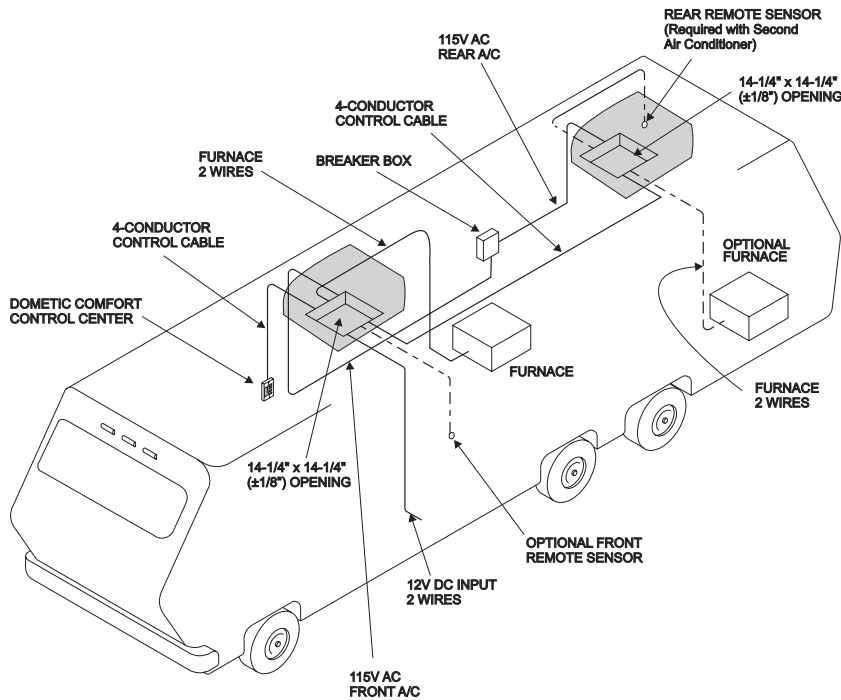

7. PLACING THE AIR CONDITIONER ON THE ROOF

- A. Remove the air conditioner from the carton and discard carton. The unit mounting bolts and literature are in separate plastic bag. Be sure to place this information in the RV.
- B. Place the air conditioner on the roof.

FIG. 7

Please Recycle All Cardboard

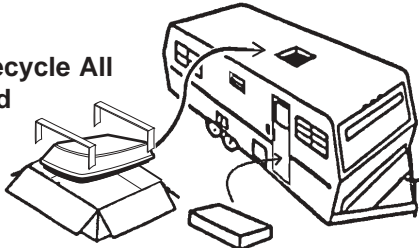

CAUTION

This unit weighs approximately 100 pounds. To prevent back injury, use a mechanical hoist to place air Conditioner on roof.

- C. Lift and place the unit over the prepared opening using the gasket on unit as a guide. The roof gasket on the bottom of the base pan goes toward the front of the RV. Sliding the unit on the roof will damage the roof gasket. See FIG. 8.

FIG. 8

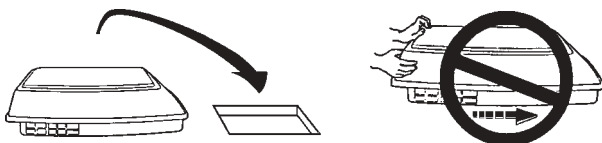

CAUTION

Do not slide the unit. This may damage the neoprene gasket attached to the bottom and create a leaky installations.

D. AIR DISTRIBUTION DUCT INSTALLATION

1. Install the Air Distribution Ducts in the RV Roof Cavity. The Distribution System must meet:
 - a. RV's requirements
 - b. System requirements listed in Section 4 on page 6 of this Manual. Terminate the start of the Duct at the back edge of the 14-1/4" x 14-1/4" ($\pm 1/8$ ") opening previously cut. See FIG. 2, 3 & 4.

8. INSTALLATION OF COLD CONTROL

A. 579, 590, 591 AND 595 SERIES

1. Insert the **Freeze Control Sensor** approximately 1" into the fins of the evaporator coil as shown in FIG. 9. Bend fins over sensor to secure in place.
2. Plug the freeze control sensor cord into the mating connector on the **Electronic Control Kit**. These connectors are polarized and will easily snap together. **DO NOT FORCE**.

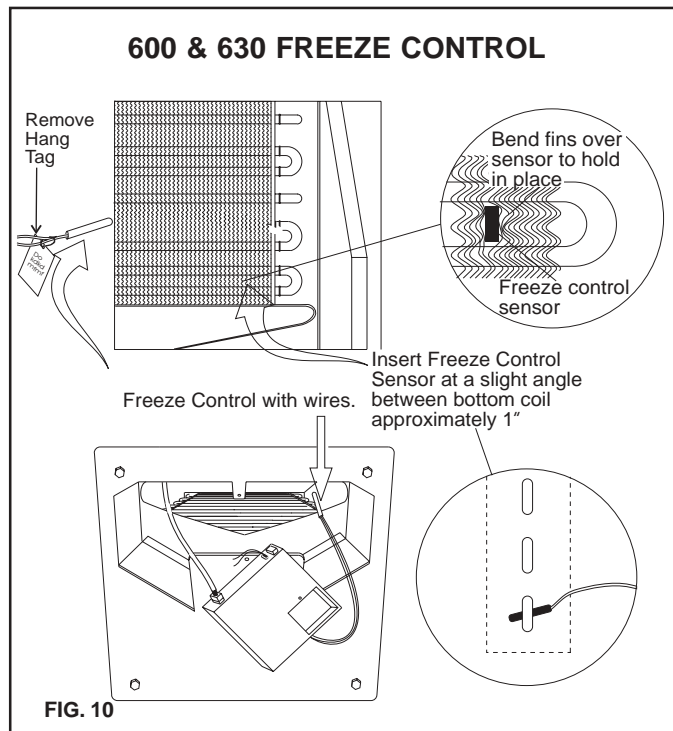
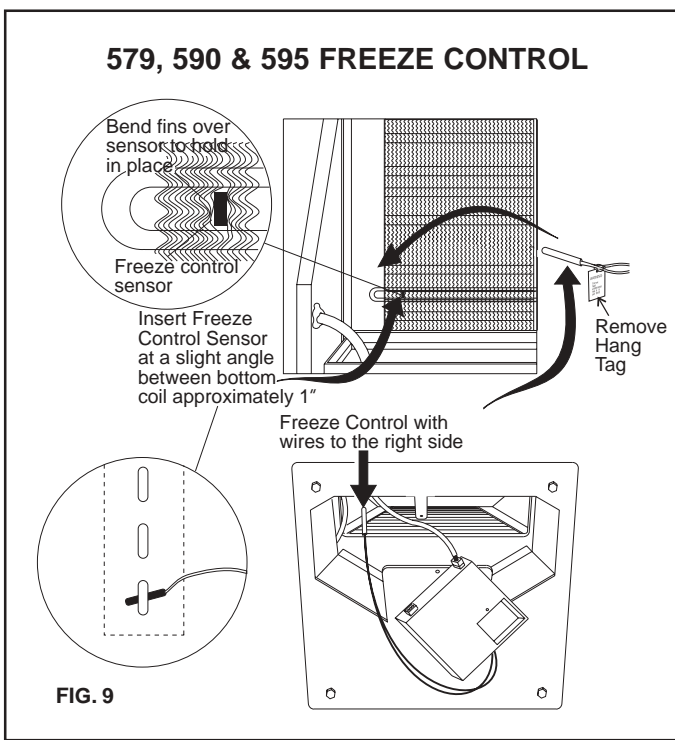

B. 600 & 630 SERIES

1. Insert the **Freeze Control Sensor** approximately 1" into the evaporator coil fins located at the right side of the evaporator, as shown in FIG. 10. Bend fins over sensor to secure in place.
2. Plug the freeze control sensor cord into the mating connector on the **Electronic Control Kit**. These connectors are polarized and will easily snap together. **DO NOT FORCE**.

8. WIRING OF CONTROL SYSTEM

A. CONNECTION OF 115 VOLT AC SUPPLY

1. Reach up into the return air opening of the air conditioner and pull the unit electrical cord down for later installation. See FIG. 11.

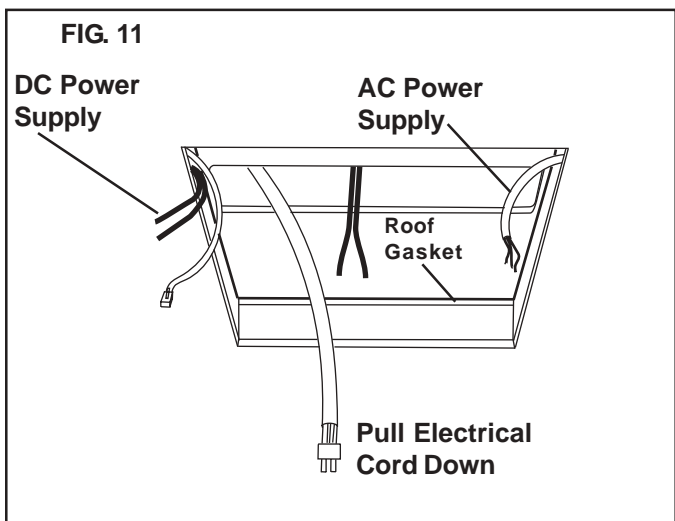

⚠ WARNING
 Disconnect 115 volt AC. Failure to follow these instructions could create a shock hazard causing death or severe personal injury.

⚠ WARNING
 This product is equipped with a 3-wire (grounded) system for protection against shock hazard. Make sure that the appliance is wired into a properly grounded 115 volt AC circuit and the polarity is correct. Failure to do so could result in death, personal injury or damage to the equipment.

INSTALLATION INSTRUCTIONS DUCTED CCC

2. Route the previously run AC power supply line through the Romex Connector and into relay control junction box.
3. Connect the white to white; black to black; and green to green or bare copper wire using appropriate sized twist wire connectors. Tape the twist wire connectors to the supply wiring to assure they do not vibrate off.
4. Tighten screws on Romex connector being careful not to pinch and cut into the insulation on power supply leads.
5. Push excess wires into junction box. Install junction box cover. See FIG. 11 and 15B.

B. CONNECTION OF LOW VOLTAGE WIRES

CAUTION

Disconnect the positive (+) 12 volt DC terminal at the supply battery. Damage to equipment could occur if the 12 volt DC is not shut off.

1. Connect the previously run +12VDC to the red wire labeled +12V protruding from the air conditioner (Do not connect wires if using the 3308120.XXX Genesis Air Filtration System).
2. Connect the previously run -12VDC to the black wire labeled -12V protruding from the air conditioner (Do not connect wires if using the 3308120.XXX Genesis Air Filtration System).
3. Connect the two (2) blue wires from the air conditioner to the furnace leads (if applicable). Polarity does not need to be observed on the furnace leads.
4. Connect the air conditioner yellow wire to the EMS wires (if applicable). Do not allow the yellow wires to short out or touch, because the compressor will fail to run.
5. Connect the Comfort Control Center™ (CCC) cable previously terminated (see Section 6 B. Control Cable) into one of the control cable leads out of the air conditioner. Either one of the two (2) control cables can be used.
6. Connect the remote temperature sensor lead into the remote sensor extension from the air conditioner (if applicable).
7. Connect the previously terminated (see Section 6. B Control Cable) 4 conductor control cable into one of the control cable leads out of the air conditioner for the next zone (if applicable).
8. If the unit is a heat pump model, route the ambient air sensor cable, already installed in the base model, through the grommet in the control kit and attach it to the connector that matches its color (RED P3).

C. COMFORT CONTROL CENTER™ INSTALLATION

1. Carefully remove the base plate from the CCC. This may be accomplished by inserting a small screwdriver under the tab on the bottom edge of the front cover. See FIG. 12.
2. Insert the control cable through the hole in the base plate and mount the plate to the wall with the two screws provided. Check the alignment to ensure level installation.
3. Install the previously terminated 4-conductor control cable RJ-11 connector into the back of the CCC. Gently press the CCC onto the base plate.

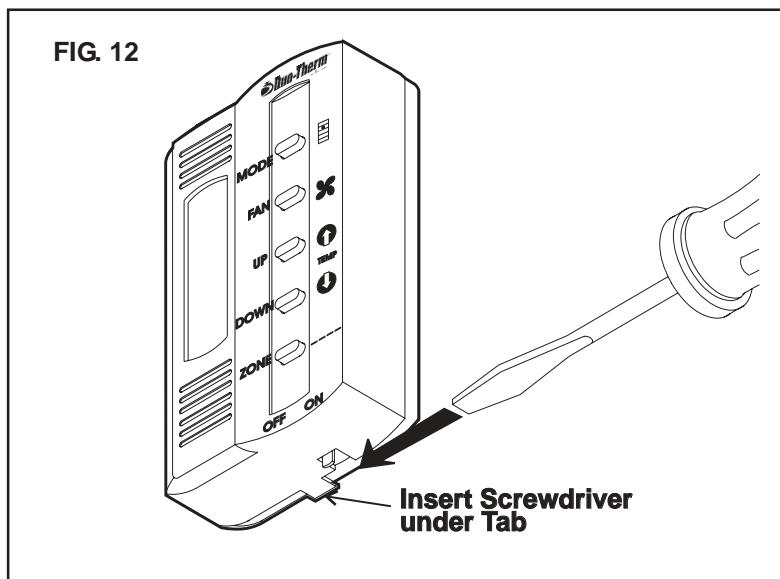

9. INSTALLATION OF AIR CONDITIONER

Installing unit with 3105007.XXX or 3105935.XXX
Return Air Cover

A. INSTALLATION OF CEILING TEMPLATE

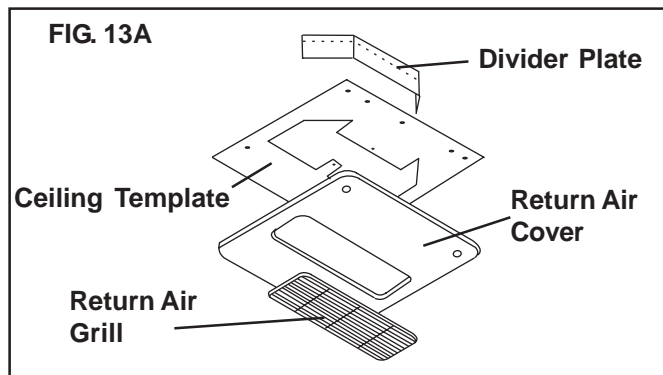

1. Check gasket alignment of the air conditioner over the roof opening and adjust if necessary. Unit may be moved from below by slightly lifting and sliding. See FIG. 14A.

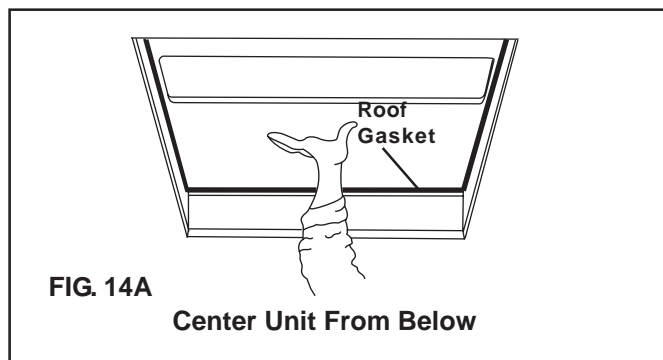

2. Remove return air cover and ceiling template from the 3105007.XXX or 3105935.XXX kit carton.
3. Locate 1/4" mounting bolts.
4. Hold the ceiling template up to the 14-1/4" x 14-1/4" ($\pm 1/8$ ") opening. Be sure the large plate faces the rear of the RV. See FIG.13A.
5. Start each mounting bolt through the ceiling template and up into the unit base pan by hand. Install wood screw in each end of the ceiling template. This insures a tight fit of the return air cover to ceiling.

Installing unit with 3105007.XXX or 3105935.XXX Return Air Cover, continued on page 14, column A.

Installing unit with 3308120.XXX Genesis Air Filtration System.

A. INSTALLATION OF FOAM DIVIDER

1. Locate the foam divider and insert it corner to corner in the 14-1/4" x 14-1/4" ($\pm 1/8$ ") opening with the adhesive tape up (Do not remove paper to expose adhesive). The foam divider should be level with the ceiling ($\pm 1/4$ "). Tear off the excess at the pre-cut perforations in divider. See FIG. 13B.

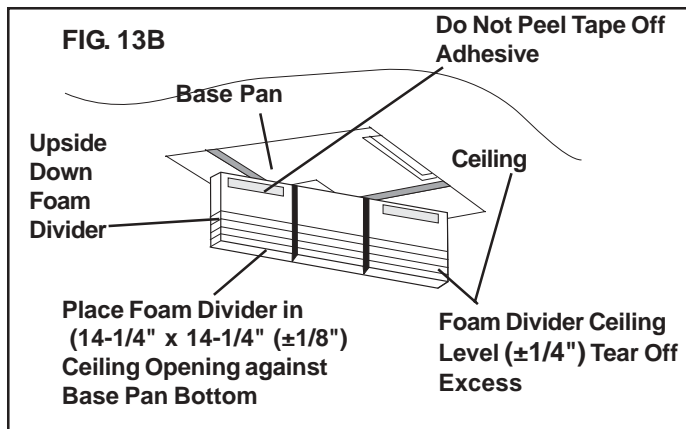

2. Peel the paper off of the foam divider and stick it in place on the center of the rear edge of the return air opening on the ceiling template See. FIG. 14B.

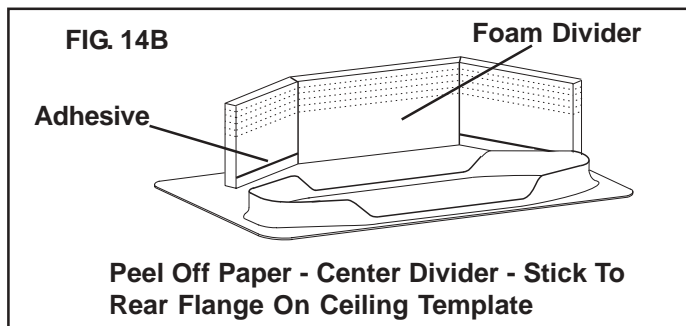

B. INSTALL CEILING TEMPLATE

1. If the Controls are not part of the unit. Set dip switches (see section 10 on page 17) and position the electrical box towards the front of the opening with all of the system control wires connected to the control box except for the DC power. See FIG. 15B.

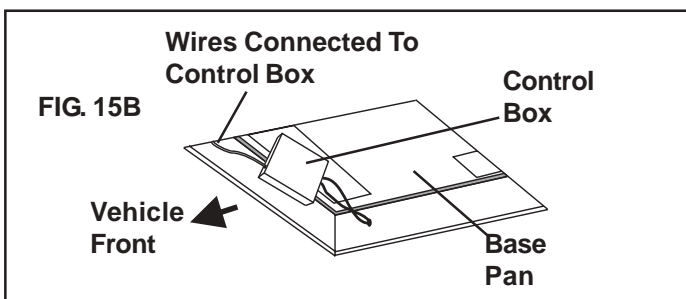

Installing unit with 3308120.XXX Genesis Air Filtration System, continued on page 14, column B.

INSTALLATION INSTRUCTIONS DUCTED CCC

Installing unit with 3105007.XXX or 3105935.XXX Return Air Cover, continued from page 13, column A.

6. Evenly tighten mounting bolts to compress gasket to 1/2" this will be a torque of 40 - 50 inch pounds. See FIG. 15A.

CAUTION

If bolts are left loose there may not be adequate roof seal or if over tightened, damage may occur to the air conditioner base or ceiling template. Tighten to specifications listed in this manual.

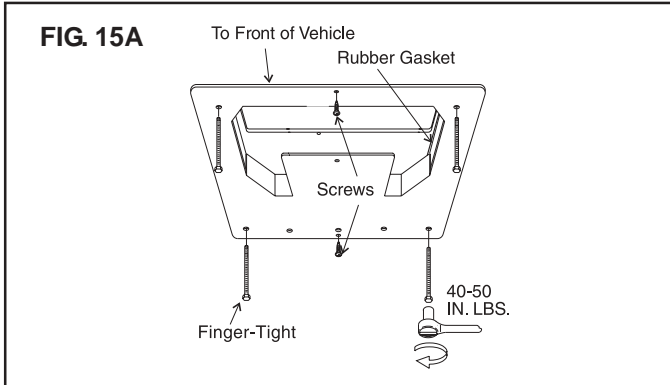

B. INSTALLATION OF DIVIDER PLATE

1. Measure the ceiling to roof thickness:
 - a. If distance is 2" - 3-3/4", remove perforated tab from divider plate.
 - b. If distance is 3-3/4" - 5-1/2", remove no tabs.
2. Remove the backing paper from double sided tape located on ceiling template. See FIG. 16A.

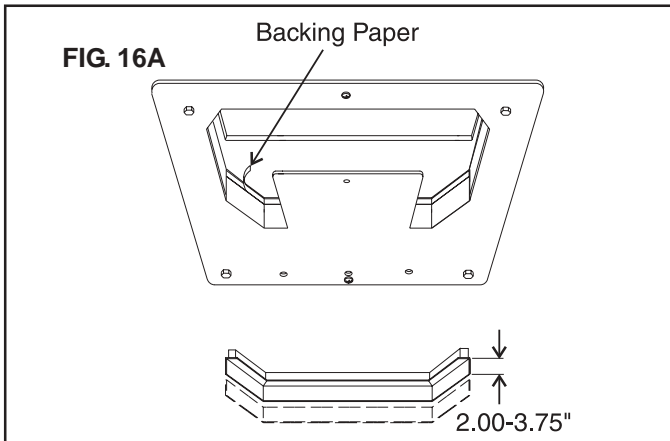

Installing unit with 3105007.XXX or 3105935.XXX Return Air Cover, continued on page 15, column A.

Installing unit with 3308120.XXX Genesis Air Filtration System, continued from page 13, column B.

2. Install relay control box on ceiling template with blunt self tapping screws depending on the model used. See FIG. 16B for Brisk Air unit, and Fig. 17B for Penguin units.

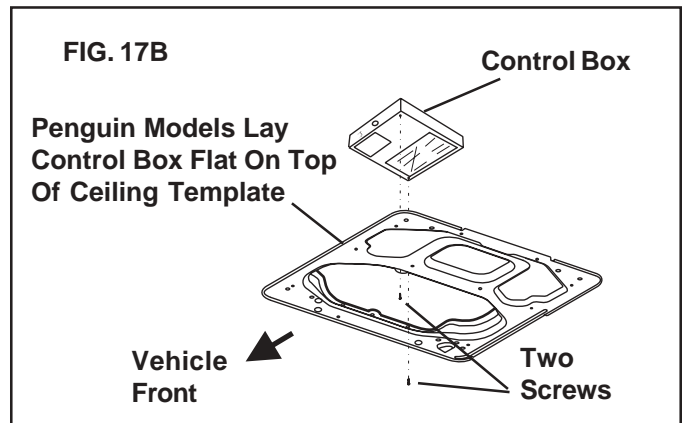
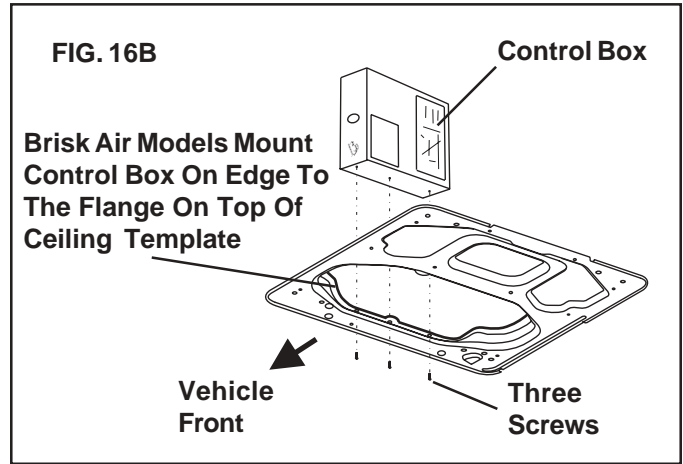

3. Start each mounting bolt through the ceiling template and up into the unit base pan by hand. **Evenly tighten mounting bolts to compress gasket to 1/2" this will be a torque of 40 - 50 inch pounds.**

CAUTION

If bolts are left loose there may not be adequate roof seal or if over tightened, damage may occur to the air conditioner/heat pump base or ceiling template. Tighten to specifications listed in this manual.

Installing unit with 3308120.XXX Genesis Air Filtration System, continued on page 15, column B.

INSTALLATION INSTRUCTIONS DUCTED CCC

Installing unit with 3105007.XXX or 3105935.XXX Return Air Cover, continued from page 14, column A.

- Place divider plate up to bottom of air conditioner base pan firmly. The foam tape on the divider plate must seal to bottom of base pan. See FIG. 17A.

CAUTION

Improper installation and sealing of divider plate will cause the compressor to quick cycle on the cold control. This may result in fuse or circuit breaker opening and/or lack of cooling.

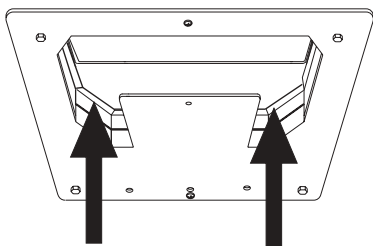

FIG. 17A

Push Divider Plate firmly onto Template

Note: The adhesive on the insulation is extremely sticky. Be sure the part is located where desired before pressing into place.

- With slight pressure then push the divider plate against the double sided tape on the ceiling template.
- Locate the 1/8" x 7" x 18" self-adhesive insulation supplied with the return air kit. Remove the backing paper from the insulation and carefully stick onto the ceiling template divider panel. See FIG. 18A.

Place insulation in position
(Do not Cover unit rating plate)

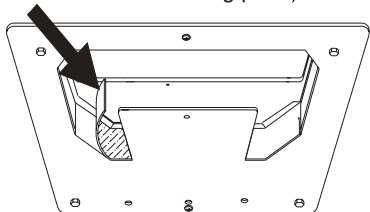

FIG. 18A

- Excess width is intended to seal the divider plate to the sides of the 14-1/4" x 14-1/4" ($\pm 1/8$ ") opening. This is to help prevent cold air discharge from circulating into the air conditioner return air opening.
- If the insulation is too high, stick excess height of insulation to the air conditioner base pan. Do not cover up unit rating plate.

Installing unit with 3105007.XXX or 3105935.XXX Return Air Cover, continued on page 16, column A.

Installing unit with 3308120.XXX Genesis Air Filtration System, continued from page 14, column B.

- Use Aluminum foil tape (not supplied) to seal the ends of the foam divider to the sides of the opening. Make sure the area behind the flange on the ceiling template is sealed. See FIG. 18B.

FIG. 18B Use Aluminum Foil Tape To Seal the Foam Divider To The Sides of 14-1/4" x 14-1/4" ($\pm 1/8$ ") Ceiling Opening

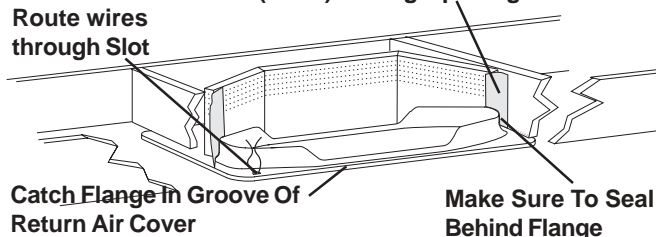

C. INSTALLATION OF INSIDE DECORATIVE COVER.

- Install the slider in the return air cover and raise it to the ceiling template. Route the wires from the return air cover through the template slot leaving about 3" between. Position wires where they can be reached after plastic cover is installed. See FIG. 18B. Place the front of the return air cover against the ceiling and slide towards the rear. The flange on the ceiling template will catch in the groove on the return cover. Adjust the position (right to left) and install the front two screws. Start and tighten the remaining screws to hold it in place.

Note: Number 10 cabinet screw can be used to replace the two front screws to hold the plastic cover flush to the ceiling. Connect together the wires from the thermostat, control box and filter indicator.

- Connect the red wire from the air conditioner the red wire from the filter indicator light with the red positive 12VDC supply wire. See FIG. 18B.
- Connect the black wire from the air conditioner, the black wire from the filter indicator light with the black negative 12VDC supply wire. See FIG. 18B.

Note: If solar panel is installed see instructions packaged with solar panel option.

Installing unit with 3308120.XXX Genesis Air Filtration System, continued on page 16, column B.

INSTALLATION INSTRUCTIONS DUCTED CCC

Installing unit with 3105007.XXX or 3105935.XXX Return Air Cover, continued from page 15, column A.

7. Position the relay control box on the tabs of the ceiling template. Secure the control box to the template with 2 blunt self tapping screws. See FIG. 19A.

C. INSTALLATION OF INSIDE DECORATIVE COVER.

1. Remove the return air grill from the return air cover.
2. Place the return air cover up to the ceiling template.
3. Install cover to template with #8 x 3/8" pointed Phillips head screws provided (6 required).

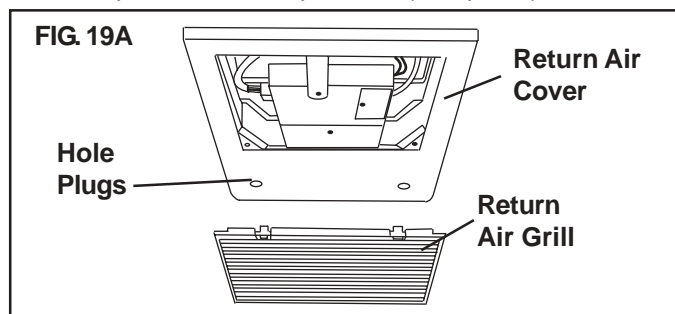

4. Reinstall filter return air air grill into return air cover. Align tabs with mating notches and snap into place
5. Install two hole plugs into screw holes in back of return air cover. See FIG. 19A.
6. This completes the installation of the air conditioner. We recommend that power be supplied to the air conditioner and check for proper operation. Refer to Operating Manual or User's Guide for a description of the air conditioner operation.

Installing unit with 3308120.XXX Genesis Air Filtration System, continued from page 15, column B.

2. Slide the filter from the right side (looking toward the RV front) over the wires. Make sure the wires are secured above the filter and are out of its way. See FIG. 19B.
3. Place grill on return air cover and snap in place. Decal is on end over circuit board.
4. Place slide handle through slots in grill into the slide posts. Handle will fit in either direction. See FIG. 19B.

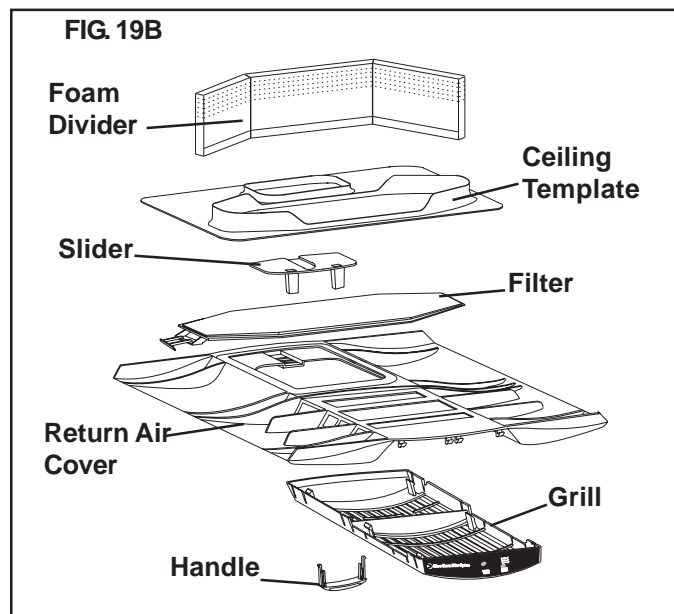

5. This completes the installation of the air conditioner. We recommend that power be supplied to the air conditioner and check for proper operation. Refer to Operating Manual or User's Guide for a description of the air conditioner operation.

10. SYSTEM CONFIGURATION, RESET & CHECKOUT

A. ELECTRONIC CONTROL CONFIGURATION

Depending on the equipment options installed by the recreational vehicle manufacturer, the appropriate dip switches will need to be switched to the "ON" position. See Fig. 20. Placing the switch in the "ON" position selects that option.

Note: Dip switches are in the "OFF" position when shipped from the factory.

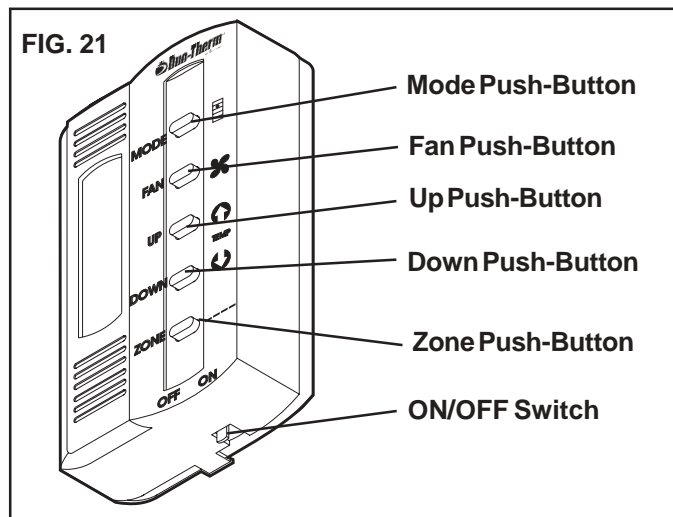
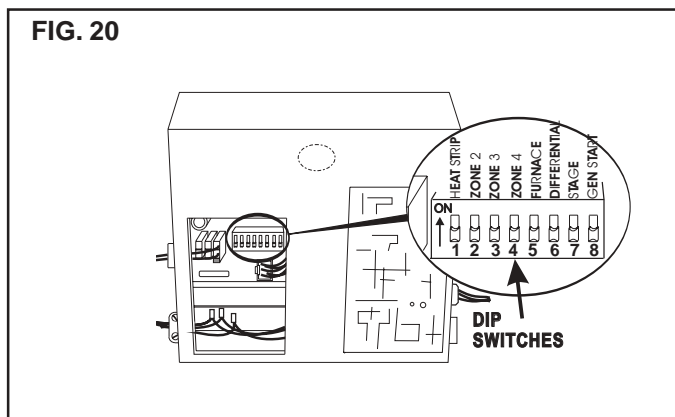

1. Zone selection - when two or more units are installed and controlled by one **Comfort Control Center™**, the second unit becomes Zone 2, the third unit Zone 3, and the fourth unit Zone 4. The appropriate zone dip switch must be set in each electronic control box for the Zone 2, 3 and 4. See FIG. 20.
2. Heat Strip selection - For units with a heat strip push the #1 dip switch to the "ON" position. See FIG. 20.
3. Heat pump models must have the red plug of the outdoor ambient sensor plugged into the RED (P3) plug.
4. Furnace selection - when a furnace has been connected to a zone, place the furnace dip switch "ON" for that zone.
5. Differential - differential is the temperature difference between the "ON/OFF" cycle of the thermostat. The normal differential is preset in the circuit board with the dip switch set to the "OFF" position. In some situations, it may be necessary to decrease the Differential. The location of the thermostat may create a condition where the normal Differential will not maintain your comfort zone. If this occurs, the Differential can be shortened by placing the Differential dip switch in the "ON" position.
Note: Setting the Differential dip switch should only be required when the installation conditions are less than desirable and is not covered under the limited warranty.
6. STAGE is not used on these units. Leave in the "OFF" position.
7. Gen start selection - leave in the "OFF" position.
8. Replace the unit electrical box cover.
9. Replace the return air cover.
10. Repeat this procedure for each additional zone.

B. SYSTEM RESET

After setting the dip switches in the electric box, do a system reset. See FIG. 21.

1. Turn the ON/OFF switch to the "OFF" position.
2. Simultaneously Depress and hold the MODE and ZONE push-buttons while turning the ON/OFF switch to "ON". FF should appear in the LCD display until the MODE and ZONE push-buttons are released.
3. When a dip switch is turned on or off after initial configuration, a system reset will need to be done before the **Comfort Control Center™** will recognize the updated selection.

C. SYSTEM CHECKOUT

Verify that all features of the installed system work. Check fan speeds, cooling mode, heat pump mode, furnace (if connected) and heat strip. If the features do not work, check all wiring and confirm that the correct options have been selected on the Electronic Control Board. See **Comfort Control Center™** Operating Instructions.

ELECTRONIC FIELD WIRING DIAGRAM

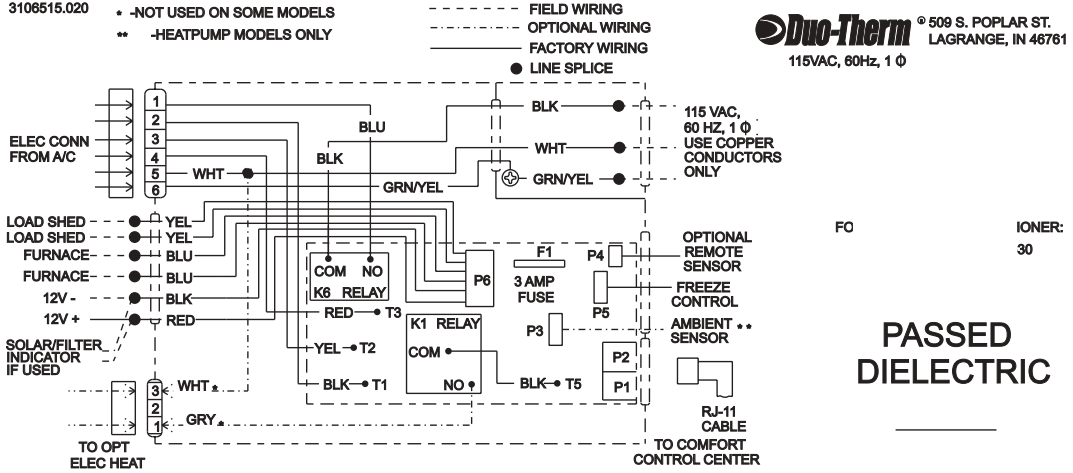

UNIT FIELD WIRING DIAGRAM (A/C)

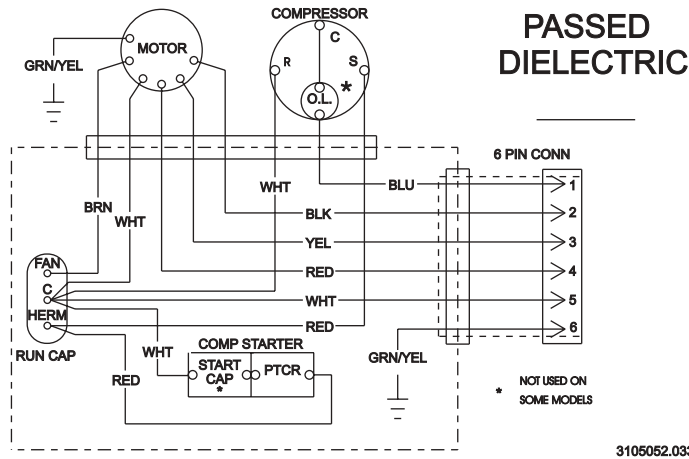

HEAT PUMP FIELD WIRING

